

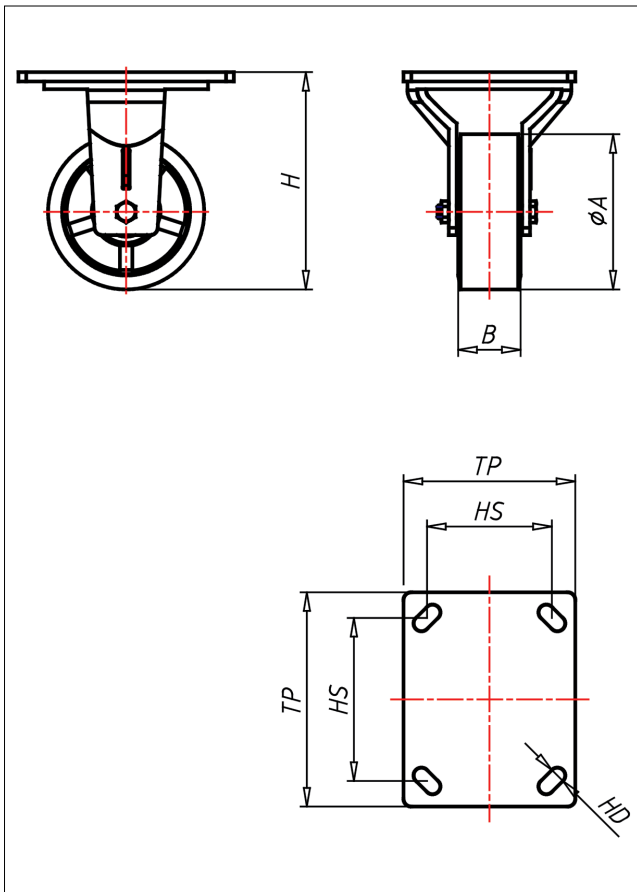

# GTF-ZK/SUB/LZK

## Bockrolle

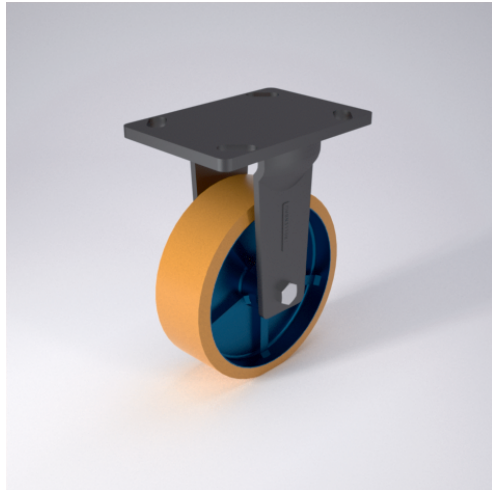

### GT-SU



LENKROLLE	RADFESTSTELLER	BOCKROLLE																				
<ul style="list-style-type: none"> <li>geräuscharmer Lauf</li> <li>geringer Rollwiderstand</li> <li>abrieb- und reißfest</li> <li>hohe Stoßfestigkeit</li> <li>sehr beständig gegen viele aggressive Medien</li> </ul> <p>Guss-Polyurethan Felge Gusseisen lackiert → Seite 247</p>	<p>Schwerlastlenkgehäuse ohne Mittelbolzen mit gehärtetem Drehkranz und gehärteten Stahlkugeln, geschmiedet und getempert</p> <p>→ Seite 42</p>	<p>AUSWAHLHILFE:</p> <table border="0"> <tr> <td>leicht lenkend</td> <td>-</td> <td>+</td> <td>++</td> </tr> <tr> <td>verschleißarm</td> <td>x</td> <td></td> <td></td> </tr> <tr> <td>stoßfest</td> <td></td> <td>x</td> <td></td> </tr> <tr> <td>bodenschonend</td> <td></td> <td></td> <td>x</td> </tr> <tr> <td>witterungsbeständig</td> <td>x</td> <td></td> <td></td> </tr> </table>	leicht lenkend	-	+	++	verschleißarm	x			stoßfest		x		bodenschonend			x	witterungsbeständig	x		
leicht lenkend	-	+	++																			
verschleißarm	x																					
stoßfest		x																				
bodenschonend			x																			
witterungsbeständig	x																					

### Technische Details

<b>ORDERNO (Artikel-nummer)</b>	GTF 100 SUB
<b>WDAB (Rad-Ø A x Breite B / mm)</b>	100x43
<b>LC (Tragkraft / kg)</b>	300
<b>H (Bauhöhe H / mm)</b>	140
<b>TP (Plattengröße / mm)</b>	138x110
<b>HS (Lochabstand / mm)</b>	105x80
<b>HD (Loch-Ø / mm)</b>	10
<b>WB (Radlager)</b>	Rollenlager